

Safety Alert



Mobile Scaffold Quick Release Claw Clamp Failure

What happened?

A worker was installing soffit sheets off a mobile scaffold. The scaffold deck was erected at 500mm above ground level.

The worker leant on the top rail whilst lifting a soffit sheet. One of the quick release claw clamps (grasper) broke and the operator fell out of the mobile scaffold.

Fortunately, due to the low height, the worker did not suffer any injuries.



Photo: Broken mobile scaffold quick release claw clamp (grasper)

What did we do immediately?

- All SBC projects were asked to suspend all mobile scaffold works until inspection of all quick release claw claps is carried out and all mobile scaffolds are confirmed as safe.
- Incident investigation is underway. The manufacturer of the mobile scaffold was contacted and asked to join the investigation team.

Safe Working Practices When Using Mobile Scaffolds

Always:

- Before commencing to erect a mobile scaffold visually inspect all components for damage and where required replace damaged components.
- DO NOT use damaged or incompatible components.
- Ensure the mobile scaffold is never used for purposes that it was not designed to be used for.
- Take good care of the mobile scaffold. Components should fit together easily without using force. Keep equipment, in particular joints and moving parts clean.
- Care must be taken when dismantling scaffold. Never let components drop or fall to the ground as the impact could cause structural damage. Misuse by dropping from height or throwing onto the back of vehicles for example can damage the claw clamps (graspers).
- Any damaged component must be reported to the person responsible for the supply of the scaffold immediately.
- DO NOT step on horizontal braces when accessing the scaffold.
- DO NOT stand or sit on midrails or guardrails.

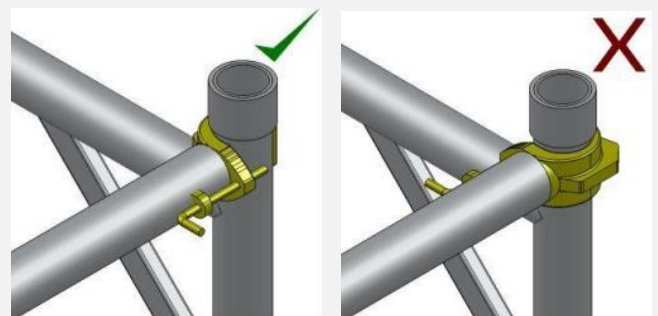

Make sure the horizontal braces (yellow) are always clipped to the *INSIDE* of the standards.