

# Uncontrolled upward movement of drill string

Petroleum and gas safety alert no. 85 | 20 February 2019 | Version Version 1

## What happened?

Two similar incidents have occurred on separate drill rigs in separate operations within a 12 month period. In both cases, while the rig was drilling out the surface casing shoe, the drill string was lifted out of the hole causing significant damage to the rig with the potential for serious injury or a fatality.

The first incident occurred in March 2018. The rig was drilling out the 9-5/8" surface casing shoe that had been set at approximately 103m. The stand pipe pressure increased to ~1,200psi (typically ~750psi) in under three seconds which resulted in the drill string moving upwards. The Top Drive System travelled 3.5m before contacting the floating crown, coming to rest and causing damage to the rig. The second incident occurred in January 2019.

Immediately following a formation integrity test, the rig was drilling out the 9-5/8" surface casing shoe that had been set at approximately 30m. After drilling out the plug the stand pipe pressure increased to 768psi (typically ~360psi) and the drill string began to move upwards out of the hole. The string moved out of hole about 3m at which time the pumps were shut in. The drill string then dropped back down causing the drill line to part and the crown saver block to fall approximately 20m and damage the drill rig floor. All personnel had evacuated the area as the emergency horn had been sounded upon the string moving out of hole.

## How did it happen?

Both incidents appear to be caused by the drilled surface casing plug lodging between the drill string and the 9-5/8" casing, blocking the tight clearance. This prevented drill fluids from circulating and caused an increase in the circulating pressure. This resulted in hydraulic pressure forcing the drill string to be lifted out of the hole. This is illustrated in the figure below. In one instance it was thought the debris was caught around the drill bit while in the other instance it was thought the debris was caught underneath the stabilizer.

## Key issues

The key issues identified were:

- The tight tolerances between the bottom hole assembly including the 8-1/2" drill bit and the 9-5/8" casing
- The shallower depth which means a low drill string weight and a lower force required to lift the string out of the hole
- Possible issues with how the plug broke up upon drilling.

## Recommendations

The recommendations from the incident investigations were:

- Reviewing the drill string design and consider running a slick bottom hole assembly when drilling out surface casing plugs
- Reviewing the design of the plug and consider the risk of the plug not breaking up upon drilling as planned
- Reducing pump rates if possible while drilling out shallow surface casing shoes
- Removing personnel from the drill rig floor while drilling out casing shoes at shallow depth
- Reviewing the design of the crown saver to reduce the risk of a dropped object.

## References and further information

*Petroleum and Gas (Production and Safety) Act 2004*

*Petroleum and Gas (Safety) Regulation 2018*

Code of practice for the construction and abandonment of coal seam gas and petroleum wells, and associated

## bores in Queensland, Version 1, 1 September 2018

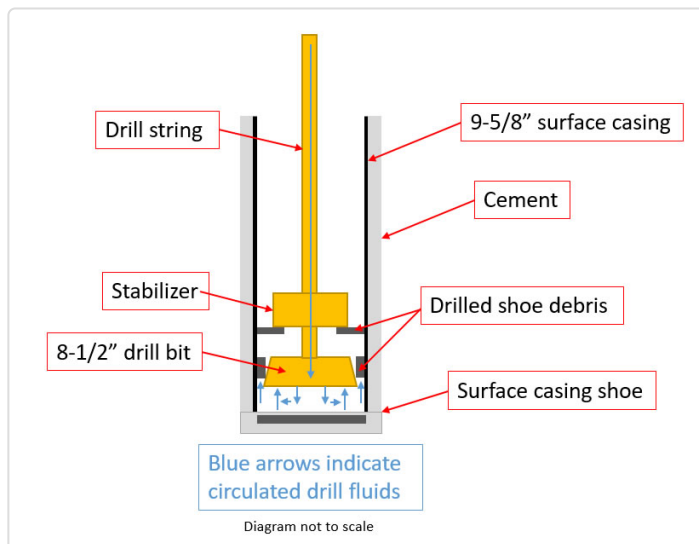
**Authorised by Bill Date - Chief Inspector**

**Contact:** Michael Scott, Principal Inspector, +61 7 3330 4204 michael.scott@dnrme.qld.gov.au

Issued by the Queensland Department of Natural Resources, Mines and Energy

General: This information is a guide only. It is not to be taken as a statement of law and must not be construed to waive or modify any legal obligation.